

**Digital
wheel balancer for
truck wheels**



**Precision and technology at your service!
Maximum efficiency, minimum effort!**



DIGITAL DISPLAY

Large display for immediate and intuitive access to all balancing programs.



SMART ARM PLUS

Intelligent system for measuring distance and wheel diameter **up to 30"**, equipped with the Fast Selection Program (**FSP**) and the new **LaserBlade** pointer.



DPA AND ELECTROMAGNETIC BRAKE

The Direct Positioning (**DPA**) function automatically sets the wheel in the correct balancing position at the end of the spin cycle, eliminating intermediate stops.

The **electromagnetic brake** simplifies the cleaning and application of the counterweights, making the mounting and demounting of the wheel **more efficient and less tiring**.



APPLICATION OF ADHESIVE COUNTERWEIGHTS

Adhesive counterweights can be applied in three different ways, depending on your preference:

- Ergonomically at **5 o'clock** using the new Laser Line Pro pointer.
- Manually at **6 o'clock**.
- Manually at **12 o'clock**, following the traditional method.

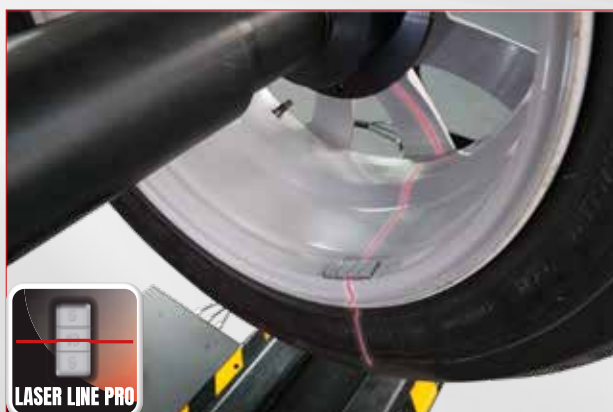

SPACE SAVING WHEEL GUARD 52"



AWD automatic sensor for contactless measurement of wheel width (optional)

ROTATIONAL WIDE WEIGHT TRAY

INCLINED FRONT PART



INTEGRATED LED ILLUMINATOR AND LASER LINE PRO POINTER



NEXT-GENERATION SPIN AND MEASURING SYSTEM

INTEGRATED WHEEL LIFTING SYSTEM



SPECIAL FUNCTIONS AND PROGRAMS

Wide range of programs for an easy and immediate use of the machine, including:

- **7 balancing programs** for alloy rims for truck and car wheels, Dynamic, Static, Hidden weight
- **2 working environments** - **Multi-operator**
- **Imbalance optimisation** (Opt Flash) - **AWC** - **Software update** via USB.

RECOMMENDED ACCESSORIES



8-21100275_GTR40 EVO

Premium steel quick nut \varnothing 40x4 mm (for MO).

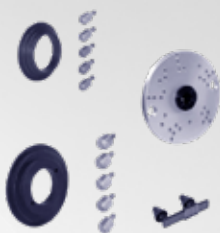

8-21100269_ART40 EVO

Premium Heavy-Duty adaptor Kit (10-8-6 hole).



8-21100293/90_AWD

AWD width sensor

For further information, consult the complete accessories catalogue

STANDARD EQUIPMENT

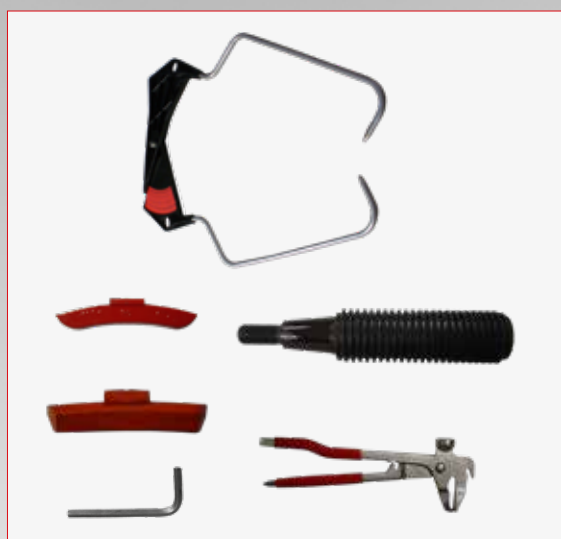

DIMENSIONS

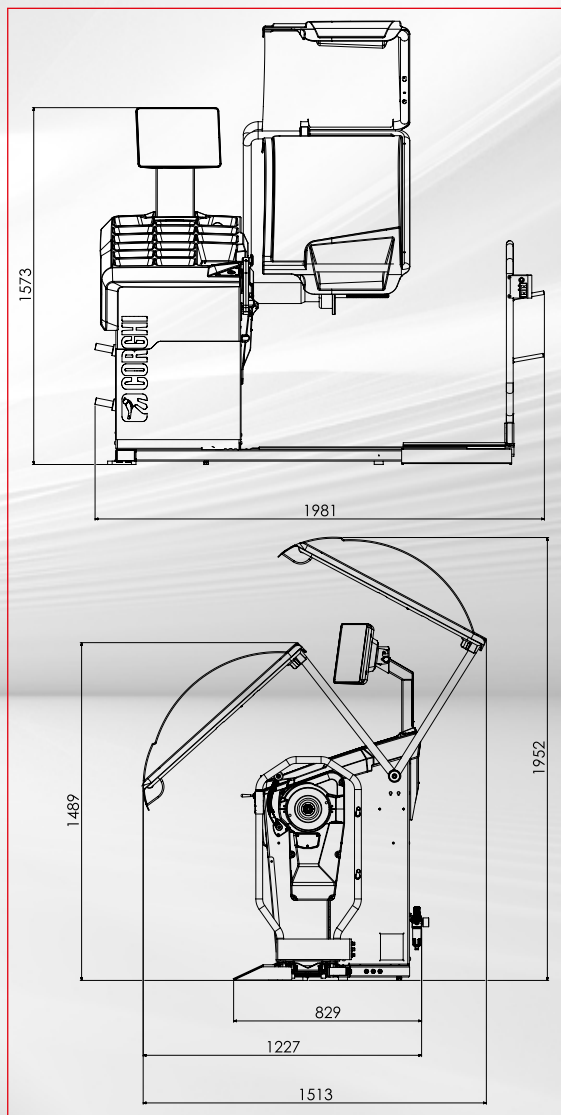

TECHNICAL DATA

Power supply	200 ÷ 230V / 1Ph / 50 ÷ 60Hz 100 ÷ 115V / 1Ph / 50 ÷ 60Hz
Total power absorption	370 W
Balancing speed	100 rpm car / 80 rpm truck
Shaft diameter	40 mm (1,57")
Supply pressure	8 ÷ 12 bar (120 ÷ 165 psi)
Average measurement time	8 ÷ 16 s
Balancing precision	1 g car / 10 g truck
Settable rim width	1,5" ÷ 20" / 40 ÷ 510 mm
Settable rim diameter	10" ÷ 30" / 265 ÷ 765 mm
Maximum wheel weight (8 bar)	300 kg (660 lb)
Maximum wheel diameter	52" / 1321 mm
Machine weight	257 kg (566 lb)

The manufacturer reserves the right to modify the features of its products at any time.