



ERCO IL 3502



3,5 t



Sollevatore elettroidraulico a doppio cilindro e sovrastruttura con bracci



Electro-hydraulic twin-ram lift and superstructure with arms





GRUPPO POMPA IDRAULICA CON MOTORE IMMERSO IN OLIO HYDRAULIC PUMP UNIT WITH IMMERSED MOTOR IN OIL

- Motore immerso in olio, **protetto da umidità** / condensa nella cassetta
- **Salita e discesa non dipendenti dal peso sollevato** grazie alla valvola di controllo del flusso
- Due valvole per un **alto grado di sicurezza**
- *Motor immersed in oil, i.e. **protected against humidity** / condensation in the cassette*
- *Lifting and lowering not depending on weight because of the flow control valve*
- *Two valves for **high degree of safety***

CILINDRI INVERSI - INVERTED CYLINDERS

- **Guarnizioni interne e anelli di guida**, ben **protette dagli agenti esterni**
- Tubo del cilindro e pistone ingranaggi cromati a fondo (copertura cromata min. 30 µm) per la **massima protezione dalla corrosione e scorrimento facilitato**
- **Lunga durata** della tenuta del pistone
- *Internal sealings and guiding belts, thus well **protected against outside influences***
- *Hard-chrome plated cylinder tube and gear piston (min. 30 µm chrome covering) for a **maximum corrosion protection and easy gliding***
- *Long lifetime of piston sealing*



DISPOSITIVI DI SINCRONIZZAZIONE E SICUREZZA SYNCHRONIZATION AND SAFETY DEVICES

- Sistema **sincronizzazione a leve collegate**
- Sistema di **controllo sicuro dell'altezza** con sensore a trasmettitore di impulsi
- ***Synchronization** system by means of **connected levers***
- ***Safe height control system**: sensor with impulse transmitter*

ERCO IL 3502

UNITÀ DI CONTROLLO A PULSANTI PROGRAMMABILE - PROGRAMMABLE PUSH BUTTON CONTROL UNIT

- Discesa di emergenza pneumatica **di serie**
- **Max. altezza di sollevamento e segnale di allarme** (arresto CE) liberamente **programmabili**, per finecorsa meccanico
- **Indicazione di errore** tramite sequenza di allarmi in caso di disfunzione

- *Pneumatic emergency lowering for power-off lowering, as **standard***
- ***Max. lifting height and alarm signal** (CE-stop) freely **programmable**, for mechanical end stop*
- ***Error indication** via alarm sequence in case of disfunction*



CASSETTA IN ACCIAIO - STEEL CASSETTES

- Le cassette in acciaio vengono consegnate con **certificazione di impermeabilità**
- Pre-montaggio dell'unità idraulica (a richiesta)

- *Steel cassettes are delivered with **waterproof certification***
- *Pre-fitting of the hydraulic unit (optional)*



SOVRASTRUTTURA - SUPERSTRUCTURE

- **Bracci telescopici a tre stadi** (due sfili) grigio RAL 7016
- Sistema interno di bloccaggio del braccio
- Altezza minima inferiore a 100 mm

- ***Double telescopic arms** grey RAL 7016*
- *Internal arm locking system*
- *Low minimum height under 100 mm*



DATI TECNICI - TECHNICAL DATA

Capacità di sollevamento	Lifting capacity,	3.500 kg
Lunghezza corsa	Stroke length	1.950 mm
Altezza di lavoro	Working height	2.020 mm - 2.085 mm
Diametro dei cilindri	Cylinder diameter	2 x 123 mm
Tempo di salita / discesa	Lifting / lowering time	~ 30 sec.
Profondità della fondazione	Foundation depth	2.625 mm
Unità pompa	Pump unit	3,0 kW
Olio idraulico	Hydraulic oil	10 l
Tensione di alimentazione	Supply voltage	230-400V / 3PH +N+PE / 50Hz / 16A

ACCESSORI RACCOMANDATI - RECOMMENDED ACCESSORIES



Olio idraulico 10 l
Oil filling 10 ltr



Set di cavi 10 m
Set of cables 10 m



x4

Set di estensioni tamponi
50 mm (4 pz)
Set of lifting pad extensions
50 mm (4 pcs)



x4

Set di estensioni tamponi
100 mm (4 pz)
Set of lifting pad extensions
100 mm (4 pcs)

Altri accessori a richiesta Other optional accessories

- Vasta scelta di tamponi opzionali
- Large program of extra pads

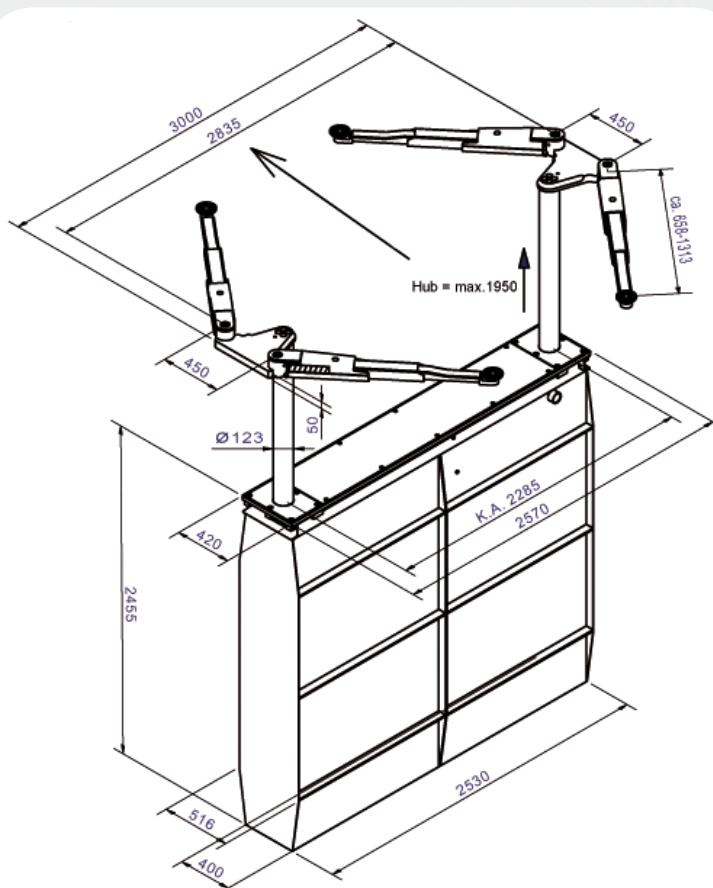

Per aiutare il pianeta ottimizzando il consumo di carta, i nostri cataloghi sono consultabili sul sito www.corghi.com. Una stampa responsabile aiuta a preservare l'ambiente.
To protect the planet and reduce paper usage, our catalogues are viewable online at the website www.corghi.com.
Printing responsibly contributes to saving the environment.

Fotografie, caratteristiche ed i dati tecnici non sono vincolanti, possono subire modifiche senza preavviso.
The manufacturer reserves the right to modify the features of its products at any time.
Cod. **DPC6001095A** 06/2020



NEXION SPA - www.corghi.com - info@corghi.com

